

# G Force Control Box V4

PCB V1.1  
Firmware V1.72

## Table of Contents

1.Avertissement .....	2
2.Contenu.....	2
3.Branchement.....	2
4.Présentation de la Control Box.....	4
5.Paramétrage des drivers .....	4
Procédure pour modifier les paramètres .....	<b>Erreur ! Signet non défini.</b>
6.Paramétrage de Simhub .....	6
7.Power Reset.....	7
8.Panneau de contrôle .....	8
Etat de connexion de Simhub : .....	8
Les switchs permettent d'activer différentes fonctions .....	8
Potentiomètres.....	8
9.Leds d'état.....	9
10.G latéraux.....	9
11.Emergency-Stop.....	9
12.Troubleshooting.....	10

# 1. Warning



The belt tensioner is equipment that requires careful handling due to the risk of injury or property damage from mechanical or electrical hazards. Before use, it is essential that users fully understand how it operates.

To minimize risks, strict safety procedures must be followed. The device will only operate when it is active and connected to SimHub.

Ensure that all components are properly installed and configured before use. Each component is designed to operate within specified power limits. Using non-compliant cables will void the warranty.

# 2. Package Contents

- 1) Control Box with driver power cable
- 2) Control panel
- 3) DB25 male-to-male cable
- 4) USB-B cable
- 5) 220V power cable
- 6) Control panel mounting brackets

**!** It is mandatory to use the supplied cables. DB25 and HDMI cables are not standardized and cannot be replaced with off-the-shelf alternatives.

### 3. Wiring

The Control Box manages driver power via a relay. The power connector must be connected to 220V mains using the supplied cable. An EMI filter is integrated into the Control Box.

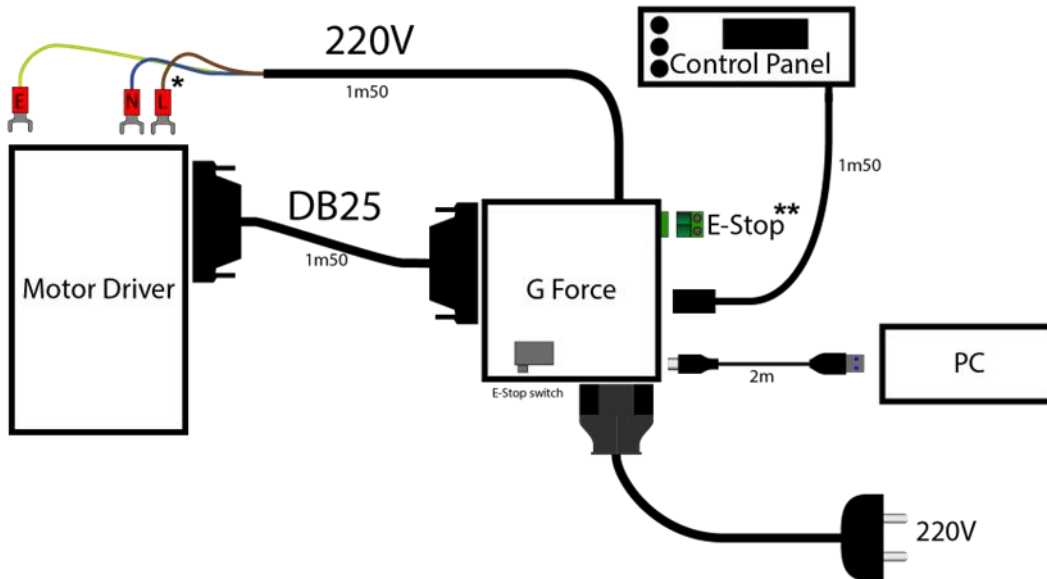

Driver power wiring depends on the driver model (standard black or silent white). Refer to the tensioner documentation on the website.

	Color	Black driver	White driver
Phase	Brown	R	L1
Neutral	Blue/black	S	L2
Earth	Yellow/Green	Terre	Terre

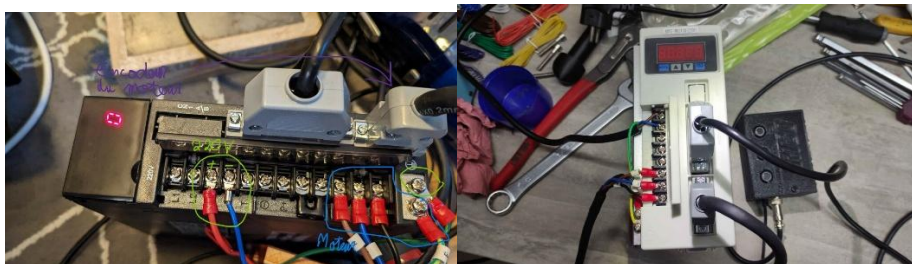

\*\* ⚠ The E-Stop is not included (see section 11).

The Control Box can manage two motors (lateral G). This is optional: if using only one motor, any DB25 port can be used.

✗ Do not use a USB hub.

✗ The Control Box cannot operate without the Control Panel connected.

## 4. Control Box Overview

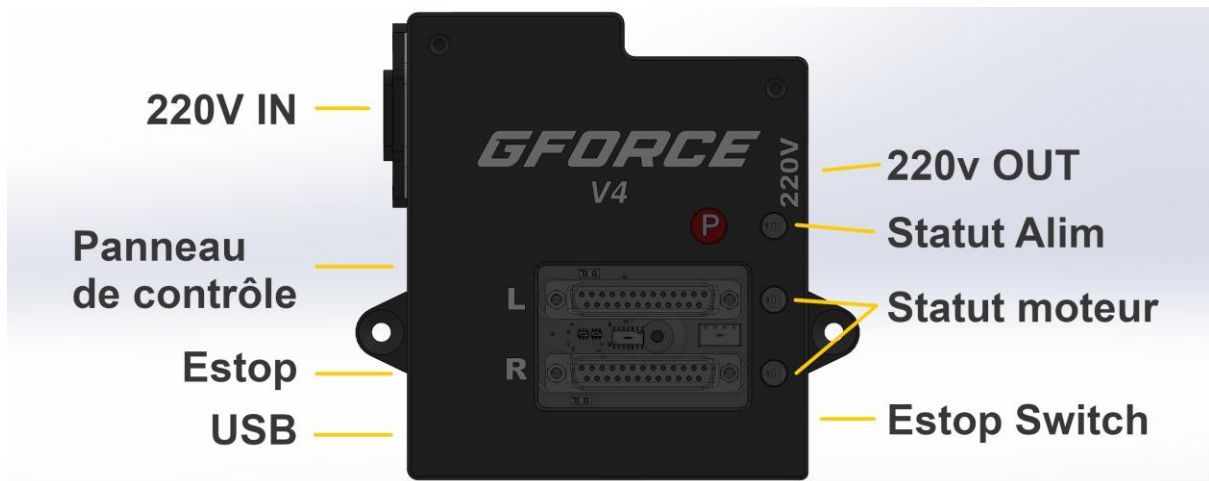

The **P button** allows manual power activation.

**⚠ WHEN THE CONTROL BOX IS POWERED, TERMINALS ARE LIVE AT 220V AND MUST BE HANDLED WITH EXTREME CAUTION.**

The **Power Status LED** indicates relay state:

- Red → relay closed → 220V is supplied
- If plugged into mains → output is live

## 5. Driver Configuration

All parameters below are required.

### Setup:

- Connect all cables
- Ensure no electrical hazard
- Hold **P button**
- Enter parameters

**⚠** If **AL09 error** appears → incorrect configuration

You can still configure. After setup → power cycle the system.

Parameter	Value	Description	Notes
Pn001	4 or 6	Motor selection	4 = 80st-M02430 / 6 = 80st-M04025
Pn002	0	Control mode	Torque mode
Pn003	0	Driver enable	0 : driven by the Gforce 1: always on
Pn021	400	Overspeed threshold	rpm
Pn062	5		
Pn189	30	Gain (force)	Can be increased later
Pn190	0	Preload	Adjustable via control panel
Pn191	0	Rotation direction	0 : CCW

### Parameter Adjustment Procedure

- Power the driver
  - Press **MODE** → Pn000
  - Use arrows to select parameter
  - Press **SET**
  - Adjust value
  - Hold **SET (3s)** to confirm
  - Press **SET** to exit
- ← button = digit selection

## 6. SimHub Configuration

Use Custom Protocol → EDIT → NCalc:

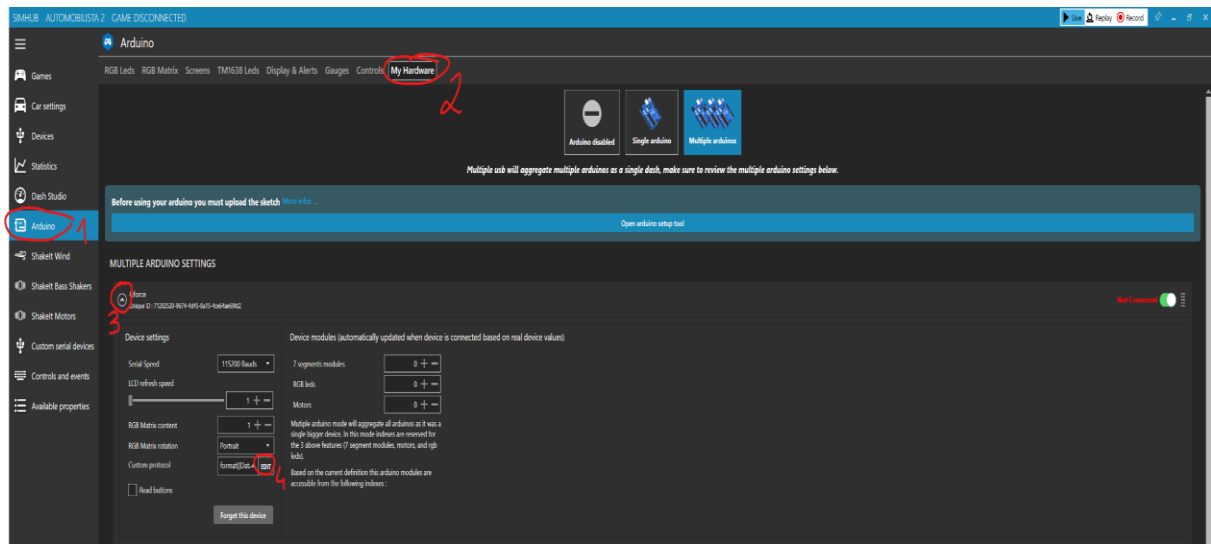

```
format([DataCorePlugin.GameRunning], '0') + ';' +
format(isnull([AccelerationSurge], '0')*2000, '0') + ';' +
format(isnull([AccelerationSway], '0')*2000, '0') + ';' +
'1' + ';' +
'1'
```

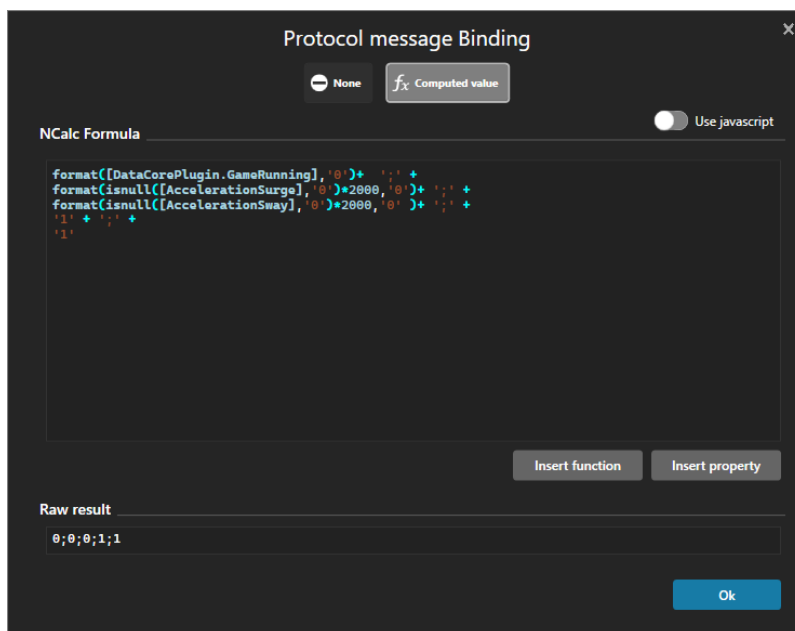

- Second last value = gain
- Last value = language (1 = French, 0 = English)
- ⚠ Only works with Custom Protocol
- ✗ Not compatible with Belt Tensioner module

## 7. Power Reset

Must be done at every session start for safety.

Drivers are active only when:

- SimHub connected
- Game running
- Power switch ON

To disable this safety → change control panel switch

- Green "S" → reset required
- Red "S" → not required

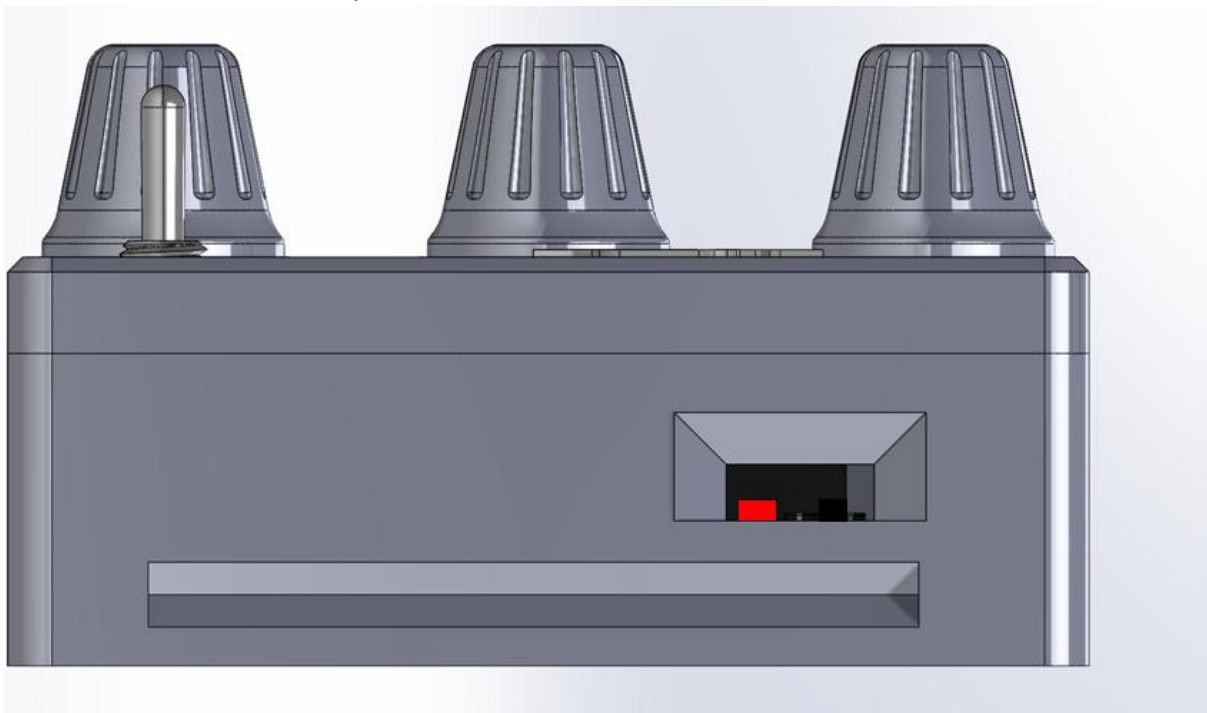

## 8. Control Panel

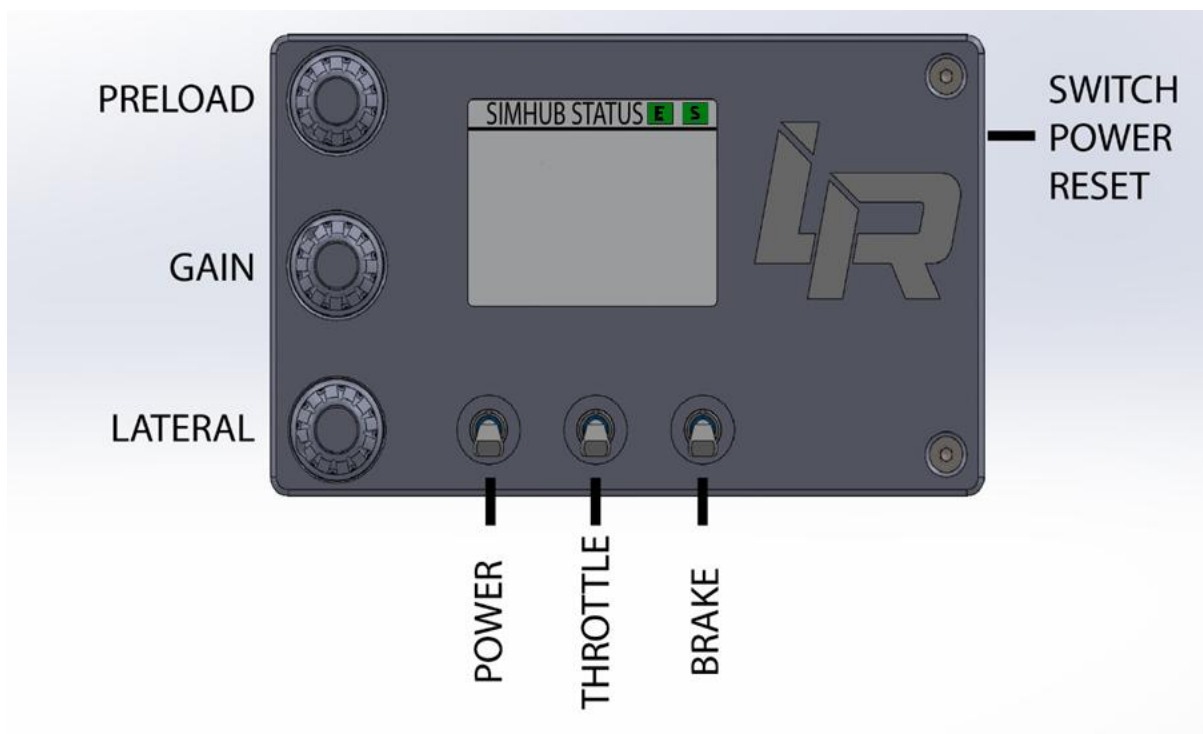

Le panneau de contrôle permet de régler le tenseur en direct.

### SimHub Connection Status :

- Disconnected** → screen off after 5s
- Connected** → screen ON
- Game running** → system active
- Overload detected** → reduce gain
- Turn power ON/OFF** → safety reset required

Les switches permettent d'activer différentes fonctions

- Power → enable power
- Throttle → activate on acceleration
- Brake → activate on braking

Both can be active simultaneously.

### Potentiometers

- Adjust force
- Lateral = lateral G control

Center detent = 50%

### Indicateur Estop et Power Reset

- E** → E-Stop required (green = yes)
- S** → Power reset required

## 9. Status LEDs

- P** → Power
- R** → Right motor ready
- L** → Left motor ready

## 10. Lateral G Forces

Supports 2 motors automatically.

- 1 motor → use any port
- disable lateral → set pot to minimum

## 11. Emergency Stop

Terminal provided, button not included.

⚠ Must enable via switch (near 220V input)

Default = disabled

Notes:

- E-Stop disables driver only
- Power switch cuts power + driver



# 12. Troubleshooting

## Screen black

Reconnect → boot screen should appear briefly

## Drivers off

- Check relay LED
- Check SimHub + switches

## Overload

Reduce gain (SimHub or panel)

## Erratic motor

- Check driver config
- Check DB25 cable

## Interference

Use shielded cables (driver + motor)

## No force felt

Increase gain carefully:

- panel
- SimHub
- driver (Pn189)